

**Instruction Manual for Novibra Spindles
HPS 68 Series
(L HPS 68, HPS 68, NASA HPS 68
and their energy saving versions .../3)**

This manual and other manuals as well, especially documents relating to safety, must be kept in such place where the staff in charge of operating and maintenance can consult them.

This manual and all information is the property of Novibra Boskovice s.r.o. The manual is intended for customers of Novibra company and it is forbidden to copy or distribute it or parts of it to a third person without prior written consent of Novibra Boskovice s.r.o.

Contents

Instruction Manual for Novibra Spindles HPS 68 Series (L HPS 68, HPS 68, NASA HPS 68 and their energy saving versions .../3)	1
1. Legal stipulations	3
2. General notes on safety	3
2.1. Safety precautions	3
2.2. Regional safety regulations	3
2.3. Obligatory notification	3
2.4. Maintenance work	3
2.5. Suitable clothing	3
2.6. Disposal	3
3. Spindles	4
3.1. Types of Bolsters	4
3.2. Top parts	5
3.3. Brakes	6
3.4. Tubes	6
4. Installation	6
4.1. Fitting of the spindle	6
4.2. Lubrication	7
4.3. Centering	8
4.4. Installation of plastic brakes	8
5. Maintenance	9
5.1. Installation, Lubrication, Centering	9
5.2. Internal lock (wharve safety lock)	9
5.3. Clamping crowns	9
6. Contact address	9
Appendix 1 – Recommended oils	10
Appendix 2 – Novibra spindles and other components in use	11
Appendix 3 – Take care in short	12

1. Legal stipulations

The Spindles supplied by Novibra and their accessories and equipment such as cutting (clamping) crowns, brakes, tube clutch systems etc. must be used only for the purpose they are intended for and in accordance to this manual.

NOVIBRA declines all responsibility for any damage or injury due to inappropriate or hazardous usage.

2. General notes on safety

2.1. Safety precautions

Spindles are supposed to be a part of ring spinning frame, which represents low risk, and low probability of injury of the staff.

For reasons related to operability, productivity etc. it is not possible to eliminate completely all sources of potential danger. Daily routine also demands constant attention.

It is necessary to follow the instructions in this manual and the manuals of the producers of the ring spinning frames to eliminate the risk as much as possible. All manuals, especially documents related to safety, must be kept in such place where the staff can consult them.

Appropriate steps must be taken to ensure that only authorized and trained staff has access to the machines.

Thinking about safety reduces the risk of injury and it is therefore never a waste of time.

2.2. Regional safety regulations

Local safety regulations and laws in force in the individual countries must be observed.

2.3. Obligatory notification

Should an accident occur or should it become clear that operating a spindle constitutes a potential danger (never run spindle which shows any sign of damage!), NOVIBRA must be informed immediately in writing.

NOVIBRA declines all liability for any damage that may occur due to failure to observe this regulation.

2.4. Maintenance work

Observe the maintenance regulations of the machine. During maintenance work, turn off the main or safety switch and secure it with a padlock. This prevents the machine being inadvertently switched on by a third person.

2.5. Suitable clothing

For operating reasons, it is not possible to secure all rotating or moving parts of a machine including spindles against accidents. The risk of accidents in such areas can be considerably reduced by wearing appropriate clothing.

- Do not wear loose clothing (wide open sleeves, scarves, ties etc.)
- Long hair must be specially protected.
Always wear a cap.
- Do not wear rings on your fingers or wristwatches.
- Do not carry tools in open breast pockets. These objects might drop out or fall into the machine.

2.6. Disposal

Laws and regulations in force in the particular country must be obeyed for spindle at the end of its lifetime concerning reutilization, recycling, and waste disposal. Any oil, grease, plastic parts etc. must be disposed of in accordance with the regulations in force.

3. Spindles:

Novibra HPS 68 spindle bearing has been proven in millions applications and it is suitable for even the most demanding operating conditions. Novibra spindles give the best performance:

- maximum spindle speed together with high reliability and long lifetime
- good running performance with low spindle vibration and low noise level
- low energy consumption
- considerably extended lubrication intervals, less maintenance and other benefits

3.1. Types of Bolsters:

L HPS 68 (1) For coarser yarn counts and larger tubes. For speed **up to 16 000 RPM.**

HPS 68 (2) Usual applications and speed **range up to 25 000 RPM.** However it is recommended not to exceed 18 000 RPM. This speed limit is based on the noise level.

NASA HPS 68 (3) The best performance (the lowest noise level and vibrations) and longer life time especially in case of higher speeds **up to 25 000 RPM.**

HPS 68/3 (4) Energy saving versions of both basic models. For even lower energy consumption. Speed limits are the same as for HPS 68 and NASA HPS 68 respectively.

The above mentioned is a general recommendation. For more details, see Appendix 2 or contact Novibra.

Attention!

- Never run spindle above recommended speed limits!
- Never run spindle, which shows any sign of damage!

Consequences:

- **Injury of the staff.**
- The spindle can be overloaded and damaged.



L HPS 68
Pic. 1

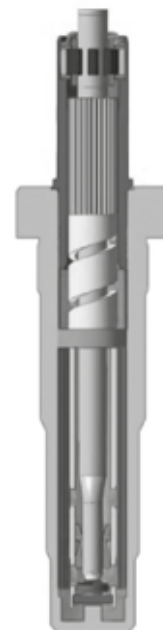

HPS 68
Pic. 2

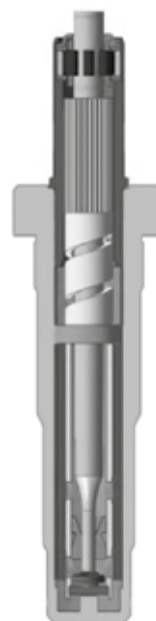

HPS 68/3
Pic. 3



NASA HPS 68
Pic. 4

3.2. Top parts:

Bare blade spindles for speed up to 16 000 RPM (Pic. 2)

Alu type spindles up to speed limits valid for the type of Bolster (Pic. 1), see chap. 3.1

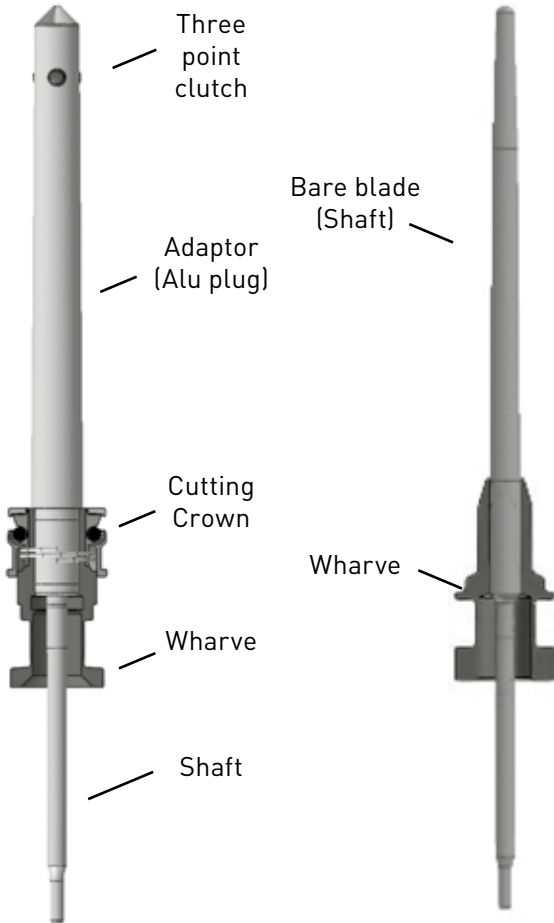

Pic. 1

Pic. 2

Belt position in relation to the neck bearing centre	+/-8 mm
Permissible belt pressure	25 N
Permissible axial load- stand still	500 N
Permissible axial load- running	30 N

Three-point clutch

Top parts can be equipped with spring (Pic. 3) or centrifugal 3-point tube clutch (Pic. 4).

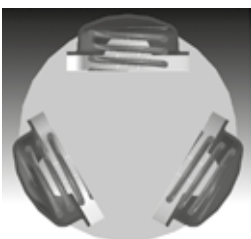

Pic. 3



Pic. 4

Safeguard of the top part

Two solutions are available - hook (Pic. 5) or internal lock (wharve safety lock, Pic. 6).

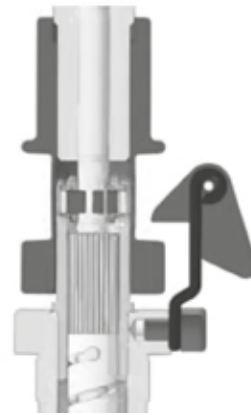

Pic. 5

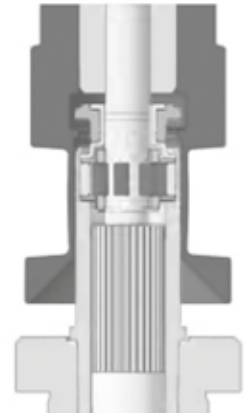

Pic. 6

For safe removal of top part and replacing of internal lock see chapter 5.2.

Cutting crowns

There is a wide range of different cutting crowns available (see examples Pic. 7).

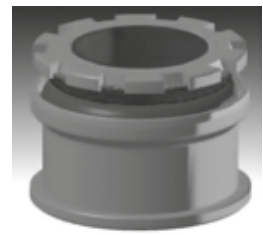

Pic. 7

For proper maintenance of crowns see chapter 5.3.

Attention!

- Never run top part, which shows any sign of damage!
- Never run top part without tube!
- Be sure that the top part is properly fixed by hook or internal lock before running!



Consequences:

- Injury of the staff.

- The tube clutch, tube, clamping crown, top part body or bolster can be damaged.
- The internal lock or hook can be damaged. This increases the risk of accident and may damage the autodofer.

3.3. Brakes:

Each spindle must be equipped with a spindle brake (Pic. 1).

Novibra can supply various types of brakes.

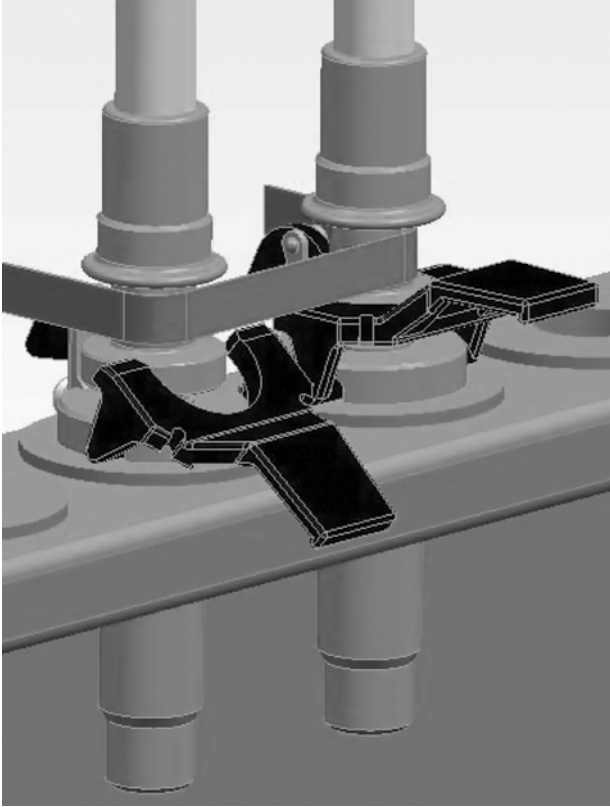

Pic. 1

Brakes must be installed properly to prevent any damage caused by wrong installation

– see chapter 4.4.

Attention!

Never stop rotating spindles or cops by hand! Always use brakes!



Consequences:

- **Injury of the staff.**
- The tube clutch or the tube itself can be damaged.
- The top part or bearings of the bolster can be overloaded and damaged.

Other recommendation:

Stop one spindle per drive tape only. Always use brake. Stop the spindle for a short time only.

Consequences of stopping several spindles:

- The spindle tape heats up and may break.
- Twist loss on other spindles.

3.4. Tubes:

The tubes have to be seen as an integral part of the spindle. Novibra spindles can withstand extreme loads but it is natural that the bigger clearance between tube and spindle creates higher load on the neck bearing and reduces lifetime of spindle. The same is valid for bent or improper tubes. This effect is increasing with higher speed.

It must be ensured that:

- Clearance between tube and spindle has to be as small as possible. Information about tube dimensions (basic dimensions and production tolerances) must be provided to Novibra for design purposes.
- Quality of tube is sufficient for target speeds. This must be ensured and guaranteed by the tube supplier.

Novibra recommends tubes which are in accordance with ISO 368.

Attention!

Never run the spindle with an unmatching tube or damaged clutch system of top part!



Consequences:

- **Injury of the staff.**
- The tube or the spindle can be damaged.

Novibra declines all liability for any damage or injury that occurred due to running spindle with unmatching tube, tube of insufficient quality or due to stopping the spindle by hand.

4. Installation

4.1. Fixing of the spindle

The tightening torque 45 Nm is recommended for standard conditions.

The maximum admissible torque for the hexagon nut is 100 Nm.

Attention!

The tightening torque for the hexagon nut must be checked regularly!

Consequences:

- **Injury of the staff.**



4.2. Lubrication

Make sure that no dirt gets into the spindle bearing. The top part can be removed from bolster only for the shortest time necessary. Take care that the removed top part cannot be damaged by rough manipulation and its shaft cannot be polluted by foreign particles or impurities.

Lubrication procedure:

- Remove the top part out of the bolster or remove the protective cap of bolster.
- Fill exact quantity of oil into the bearing. The neck bearing must be wet. Sufficient quantity of oil is essential for oiling of neck bearing. Air bubbles under the oil coil must be avoided. To ensure this the oil must be filled in at pressure higher than atmospheric.
- To check the oil quantity, use Novibra dip stick Ref. No. 850.3877 only. Insert the dry dip stick down to the very bottom of the bolster. Remove the dip stick and check if the oil level is in required range. If the oil level doesn't meet the required range, it is necessary to fill or remove the oil.
- The spindle top part must be inserted into the spindle bearing immediately after oil filling. To avoid any damage it should be checked that the top part moves smoothly in the spindle bearing without jamming and it is secured by hook or internal lock.

Specification of the oil:

Lubricating oil according to DIN 51524 HLP 10 viscosity to ISO VG 10 DIN 51519 at 40°C = 9-11 mm /sec (cST).

For more detail see Appendix 1 – Recommended oils
Lubricating oil with higher viscosity may be necessary for special spinning conditions (for tube lengths above 250 mm and simultaneous spinning of yarn counts coarser than 20 tex, or in case of spinning without anti balloon ring etc...). Contact Novibra for more details.

Frequency of lubrication:

Oil should be changed with the following Frequency – this applies only for oil acc. to DIN 51524 HLP 10:

Operating speed	Oil changing frequency
up to 15 000 RPM	after 24 000 hrs
up to 20 000 RPM	after 16 000 hrs
over 20 000 RPM	after 8 000 hrs

The frequencies given above apply to regular operating conditions. The intervals must be shorter for more demanding operating condition.

It is recommended to make random tests of the oil level minimally after half the number of operating hours stated for the oil change frequency. If the oil level is lower than the minimal level required by the dip stick, oil must be added.

The oil must be changed immediately, if the oil quality is decreased (e.g. remarkable change of oil colour)

Novibra spindles don't require any special running in procedure. Just remove plastic cup from the bolster, check oil level (add oil, if necessary) and run the spindle.

Equipment for lubrication:

Novibra Lubrico (Pic. 1) Ref. No. 959.7370 is suitable for the first oil filling and for further oil changes with simultaneous cleaning of the spindle bearing.



Pic. 1

Novibra can supply suitable lubrication inserts for all types of spindles.

Disposal of used oil:

The particular country restrictions must be obeyed and the used oil must be disposed of in accordance with valid regulations.

Attention!

- Never run the spindle without oil inside the bolster!
- The quality and quantity of the oil must be checked regularly!



Consequences:

The spindle can be damaged.

Novibra declines all responsibility for any damage or injury that occurs due to running spindle without proper lubrication i.m. with insufficient oil level or with oil which doesn't meet the above mentioned recommendations.

4.3. Centering

The precise centering of spindle and ring is more and more important for smooth running with increasing spindle speeds. Correct centering has a decisive influence on thread quality and on the number of thread breaks as well.

Manual centering devices:

Ref. No. 10384250 for HPS 68
 Ref. No. 10384251 for HPS 68/3

The best accuracy can be achieved only if centering is done while spindle is rotating.

Novibra can supply an electronic equipment Center P+ Ref. No. 10414362 (40008630) with an excellent accuracy (Pic. 1).



Pic. 1

Procedure of centering by Center P+:

- The ring rail is lifted up to position to about 1/2 of the tube length.
- The device is clamped by a ring adapter directly to the ring.
- The spindle is rotating at about 8 000 RPM
- The ring is manually centered according to the axis of the rotating spindle as long as central light shows a proper state.

Attention!

The centering can only be done by trained staff!

Consequences:

- **Injury of the staff.**



4.4. Installation of plastic brakes

Brakes must be installed properly to ensure that they won't be damaged.

Correct procedure of installation:

- Fix spindle without brake on a frame. Use special pliers Ref. No.: 851.5147 for fixing the bolster while tightening the nut (Pic. 2). **Never hold the bolster by inserted plastic brake while the nut is tightened!** It leads into damage of the brake!

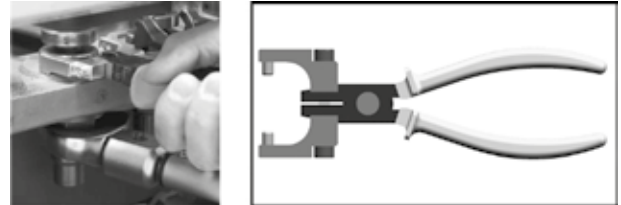

Pic. 2

- Insert only one side of the brake jaw in the bolster slot. (Pic. 3)

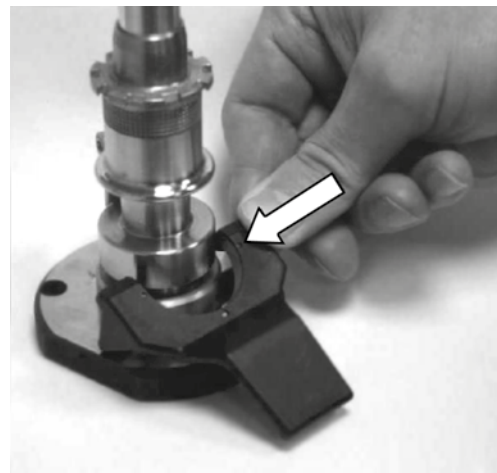

Pic. 3

- Turn the brake slowly until the other side of the brake jaw clicks to the opposite slot. (Pic. 4)



Pic. 4

- It is not possible to remove the brake out of the bolster directly - the complete bolster must be removed at first!

5. Maintenance

Novibra spindles are designed and produced for long and trouble free lifetime. However, this can be achieved only by correct handling and maintenance of spindles by spindle users.

Regular maintenance is essential for long lifetime and avoids unnecessary down time. Maintenance should be scheduled.

The most important part of maintenance is correct lubrication and proper handling with spindles during installation, lubrication, centering, cops changing etc.

Attention!

- Make sure that the machine can not be switched on by a third person during maintenance!
- If the spindle shows any sign of damage it cannot be operated!



Consequences:
- **Injury of the staff.**

5.1. Installation, Lubrication, Centering

For more details see chapter 4.

5.2. Internal lock (wharve safety lock)

The following procedure must be carried out if the retaining ring (1) shows any sign of damage and must be replaced:

- top part is gently removed by the lifting tool Ref. No.: 851.0783
- old retaining ring (1) is cut by a knife and removed
- new retaining ring (1) is assembled by set of tools: Taper pin Ref. No.: 850.8758 (2) and Punch holder Ref. No.: 850.8759 (3)
- put the taper pin (2) on the top of the bolster (4) as shown on Pic. 1. Insert new retaining ring (1) on the taper pin (2) and push it softly down by the help of the punch holder (3). Use your hands not a hammer!
- top part is carefully inserted back into the bolster

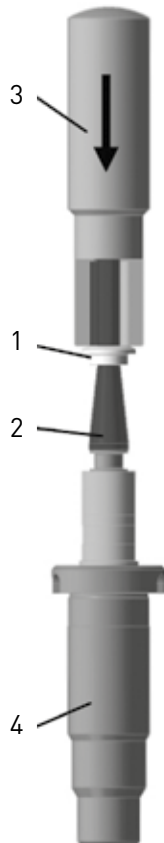

Pic. 1

Lifting tool Ref. No.: 851.0783 (2) for safe removing of top part out of the bolster must be used for spindles equipped with internal lock.



Pic. 2

Attention!

Ensure that the top part is inserted into the bolster properly and secured by the retaining ring!



Consequences:
- **Injury of the staff.**

5.3. Cutting crowns

Cutting crowns must be cleaned regularly from the yarn remnants.

This must be done by a suitable tool e.g. by a soft brush. Avoid a sharp tool for cleaning, especially if cutting crown is made of plastic!

Attention!

It is not allowed to clean the spindle while the spindle is running! The spindle must be stopped!



Consequences:
- **Injury of the staff.**

6. Contact address

Novibra Boskovice s.r.o.
Na Kamenici 2188
CZ - 68001 Boskovice

Sales

Phone: ++420 516528189
Fax: ++420 516528188
E-mail: sales@novibra.com

The data and illustrations in this brochure and on the corresponding data carrier refer to the date of printing. Novibra reserves the right to make any necessary changes at any time and without special notice. Novibra systems and Novibra innovations are protected by patents.

Appendix 1 – Recommended oil

Lubricating oil according to DIN 51524 HLP 10
viscosity to ISO VG 10 DIN 51519 at 40°C = 9-11 mm / sec (cSt).

The following suppliers and oils are recommended:

Shell: Tellus S2 MA 10

Mobil / ExxonMobil: Mobil DTE 21 HLP 10, DTE 11M, Mobil Velocite 6

Agip: AGIP OSO 10

BP: Batran HV 10 (Energol HLP-HM 10)

TEXACO: RANDO HD 10

Castrol: Hyspin AWS 10

Esso / Exxon: Nuto H10

AVIA: Avia Fluid HVI 10

Klüber: Crucolan 10

Oil quantity

For one bolster HPS 68 you can calculate approx. 4-5.8 ccm. For L HPS 68 approx. 4.5-7.2 ccm. These are rough figures only! Right quantity has to be always checked by the oil level gauge (see below)! In case of using Lubrico for lubrication you have to calculate some additional quantity of the oil for bolster cleaning.

Put the dip stick into the bolster. Do it gently and carefully. The oil level must be between max. and min. marks.

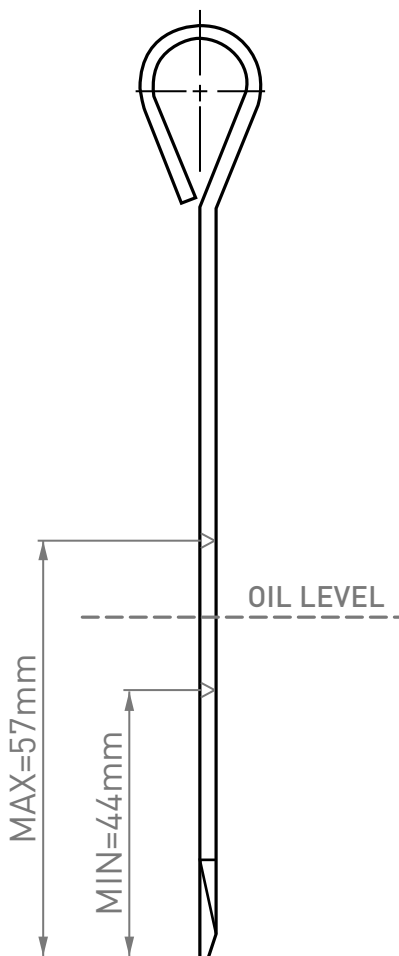

Dip stick
Ref. No. 850.3877

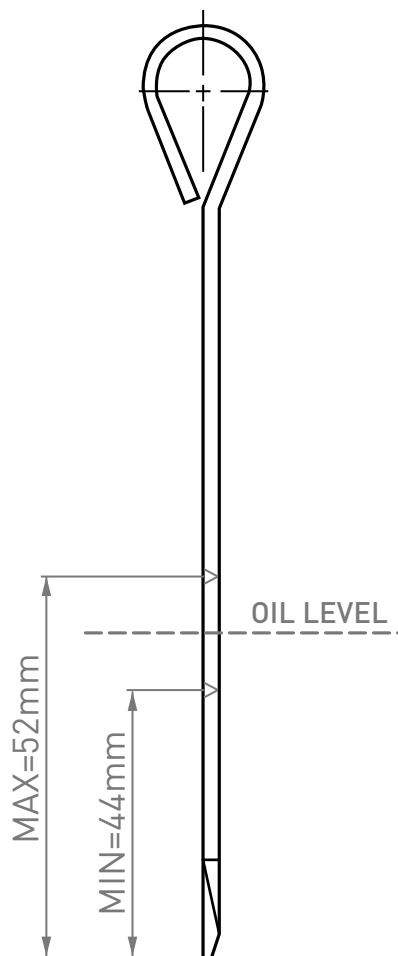

Dip stick Ref. No. 851.5145
for Rieter machines supplied by Rieter, CH.

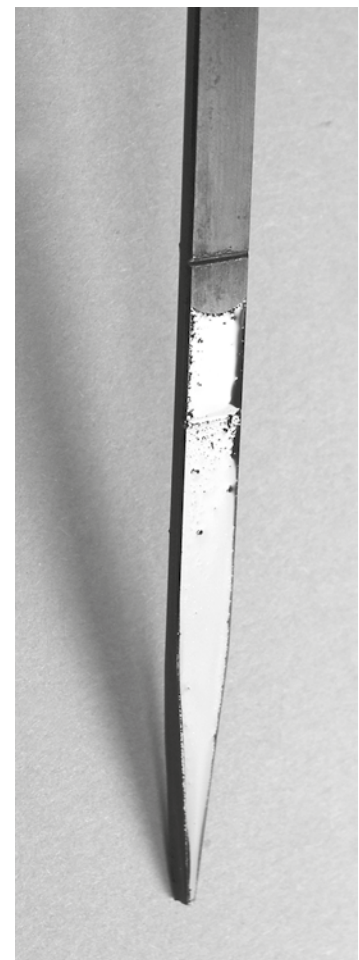

Appendix 2 – Novibra spindles and other components in use

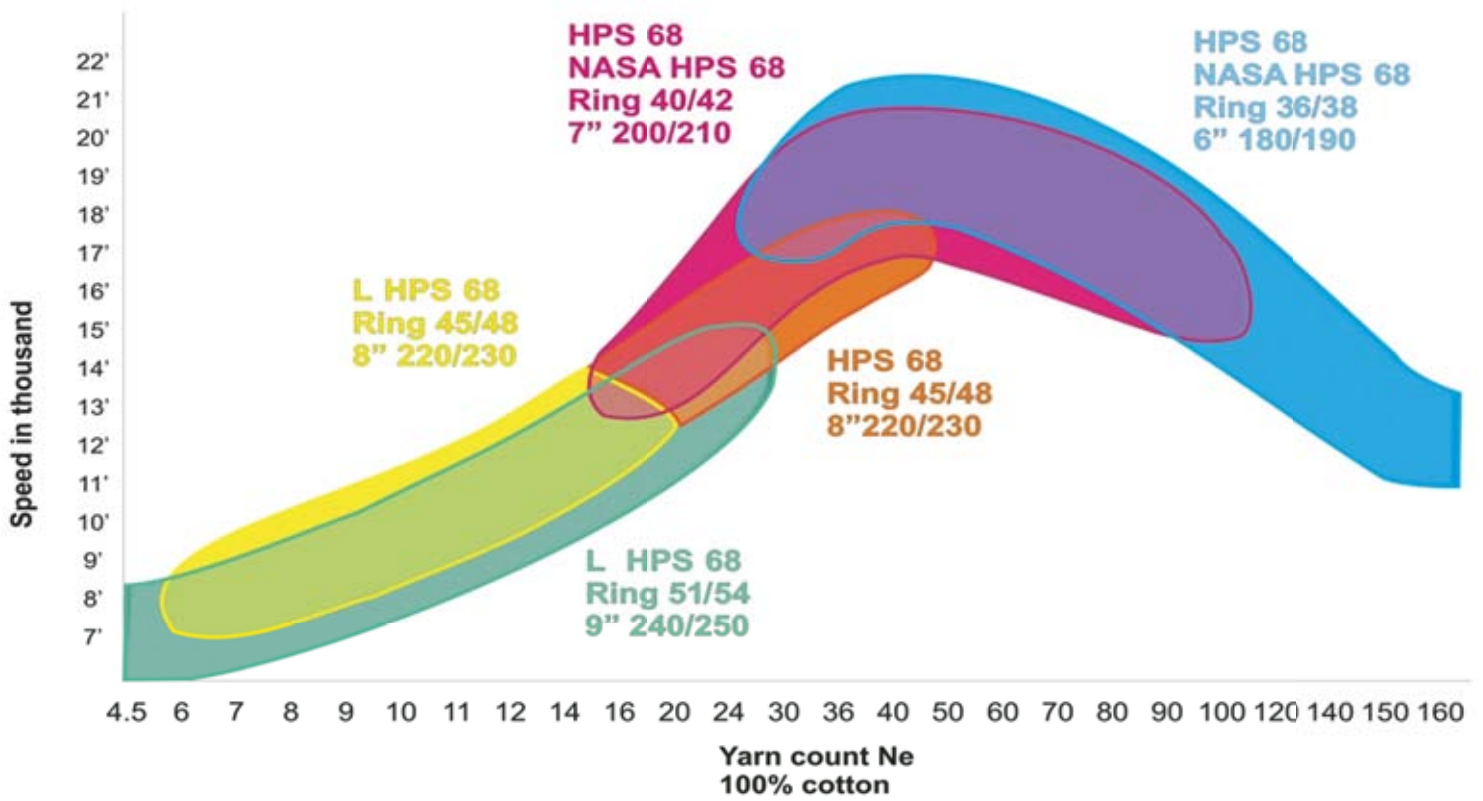

The diagram has been worked out on the basis of information collected from spinners from all around the world. It shows the most usual applications for spinning 100% cotton, conventional yarn (neither core yarn nor slub yarn).

The above specification diagram for Novibra bolsters is valid from 1.12.2011

This diagram replaces all previous diagrams and bolster specifications.

Appendix 3 – Take care in short

Use original transport boxes for deposition of spindles! Do not damage spindles by mishandling!

Use adequate forces and procedures! Do not use a hammer! Use original Novibra tools!

Tighten and lubricate the bolster properly! The tightening torque and oil must be checked regularly!



Insert the top part vertically into the bolster with adequate force!

Ensure that the top part is secured by hook or internal lock before running! Do not run spindle with damaged hook or internal lock!

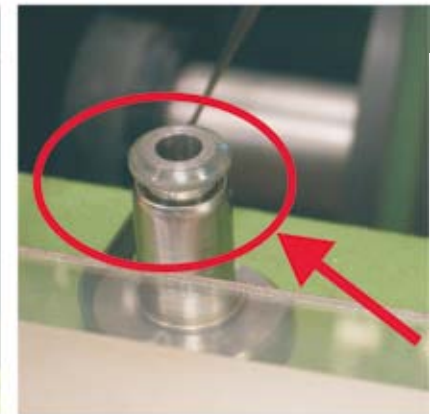
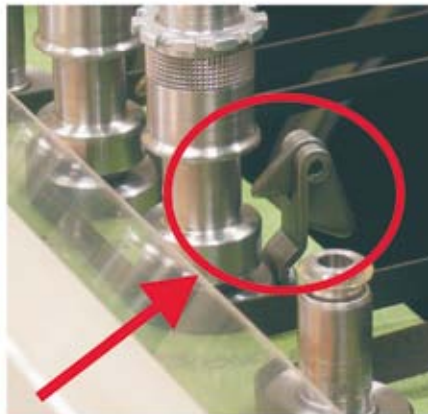
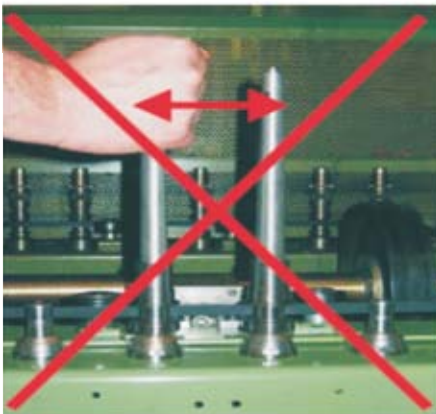

Do not run spindles without tubes or with unmatching tubes! Do not run spindles with damaged three-point clutch or damaged tubes!

Do not touch running spindle! Do not clean rotating spindle! Do not stop spindle by hand – use brake!



Never run spindles, which show any sign of damage!
For more details study the Instruction manual carefully!